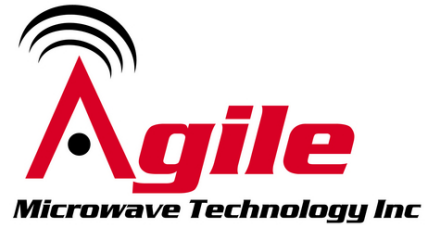


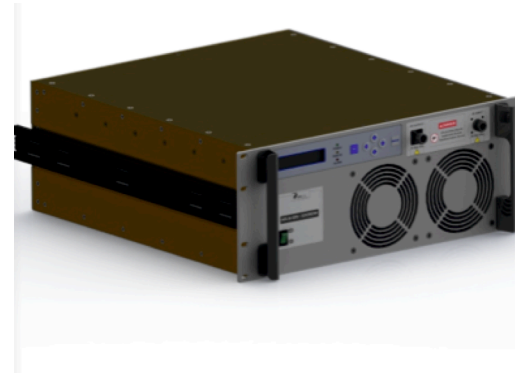
## Data Sheet

# AMT-A-501 0.7GHz to 3.0GHz Solid State Power Amplifier (SSPA) 19" 4U Rack Mounted Configuration



## Features

- SSPA 50 Watts P1dB,  
125 Watts PSAT
- The controller contains the following subsets:
  - Ethernet interface for remote control from web browser, display and
  - Keyboard for local control.
- Built to High-Reliability standards



## Description

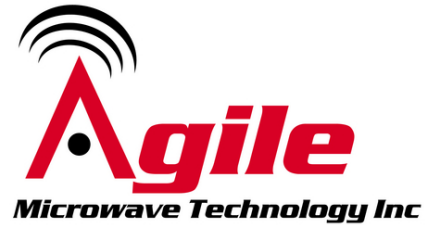
The AMT-A-501 SSPA Block Diagram is shown in Figure 1. The SSPA is packaged in a 19" 4U Rack Mount Chassis:

18 31/32" x 19 1/64" x 6 31/32" (See Figures 2 through 4)

- Keyboard and Display with LED output for power, alarms, etc.
- Preset able visual and audible alarm for power up to 47 dBm.
- Thorough CAD design Electrical, Mechanical & Thermal. Extensive testing achieve superior reliability & performance.
- Ethernet remote control.
- Linear power, over 47 dBm across the Frequency band.
- Temperature monitor and Fan Speed control

## Applications

- EMC/EMI Testing
- Satellite Uplink Power Amplifier Systems
- Communication Systems
- Microwave Radio Systems & Point-to-Point Microwave Link Transmitter Systems
- Test Equipment/ Burn-In
- Signal source to drive multiple RF modules /units
- High reliability applications



### MAXIMUM RATINGS<sup>1-3</sup>

Parameter	Symbol	Units	MIN	MAX
Operating Temperature – Case	T <sub>MO</sub>	°C	0	+50
Storage Temperature - Case	T <sub>MS</sub>	°C	-40	+60
RF Input power (CW)	P <sub>in</sub>	dBm		+10

1. Stresses above those listed under "Absolute Maximums Rating" may cause permanent damage to the device. This is a stress rating only and functional operation of the device at these or any other conditions above those indicated in the operational sections of this specification is not implied. Exposure to absolute maximum rating conditions for extended periods may affect device reliability.
2. Operating Temperature range at Sea Level. Derate linearly to 20C at 10,000 Ft.
3. 0-95% Relative Humidity and Internal Forced Air Cooling from Front to Back.

**TABLE I ELECTRICAL SPECIFICATIONS @ 23°C**

Parameter	Conditions	Units	MIN	Typical	MAX
Frequency Range		GHz	0.7		3.0
Gain	-33dbm to +0dBm	dB	47		54
Gain Flatness		dB		±1.5	±2
OIP3		dB		56	
Harmonics		dbc		-18	
Spurious		dBc			-60
RF Output Power	P1dB	dBm W	47 50		
Input VSWR	50Ω			1.8:1	2.0:1
Output VSWR	50 Ω			1.8:1	2.0:1
Primary Power Voltage Frequency Power	Power requirements	Vac Hz W	90 47	115	132 63 300

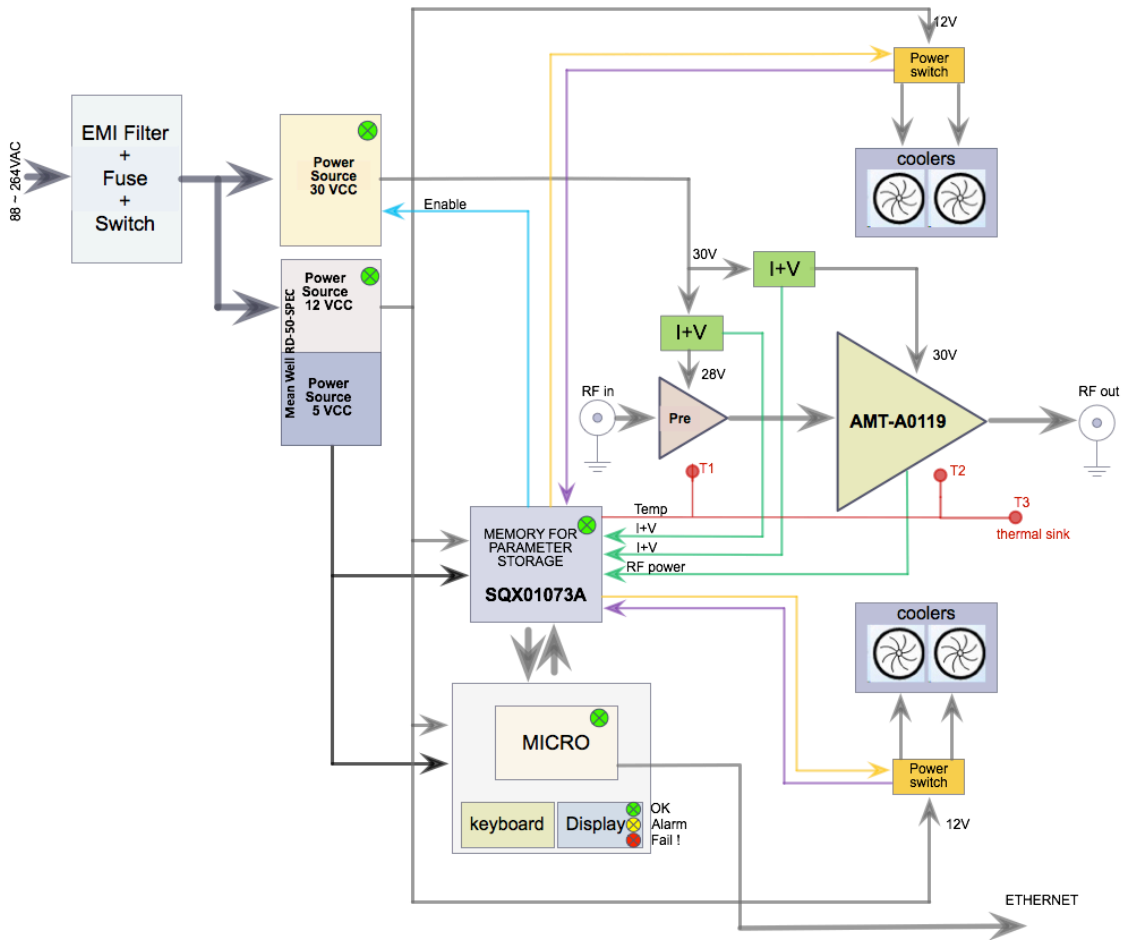
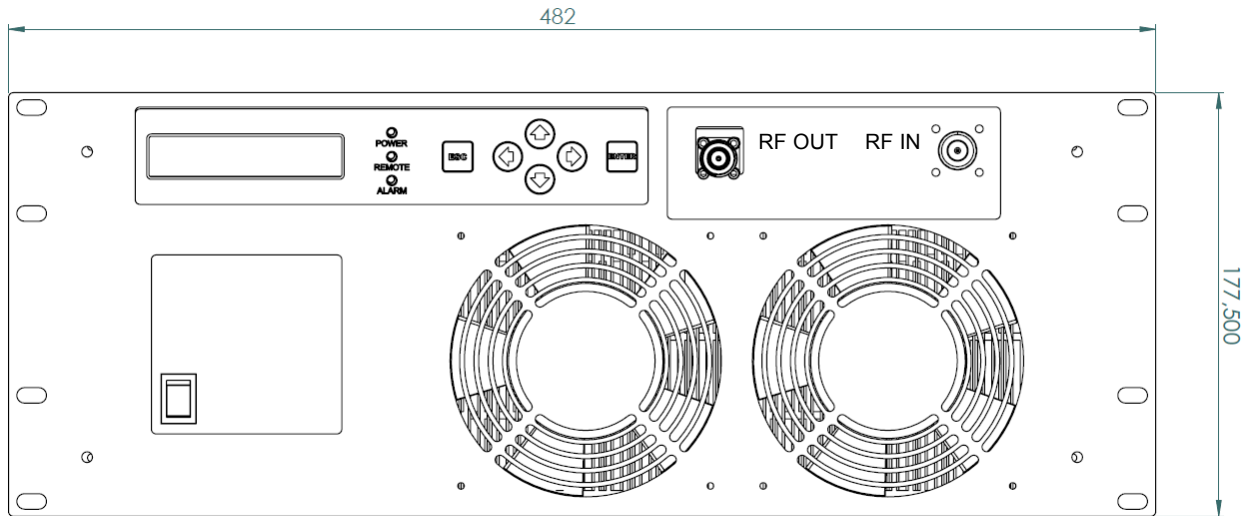
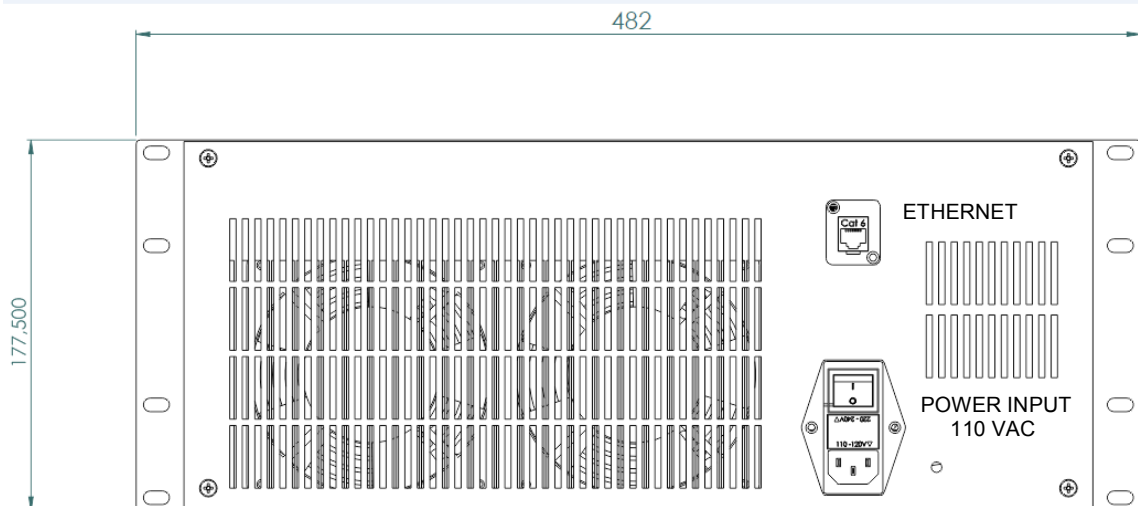


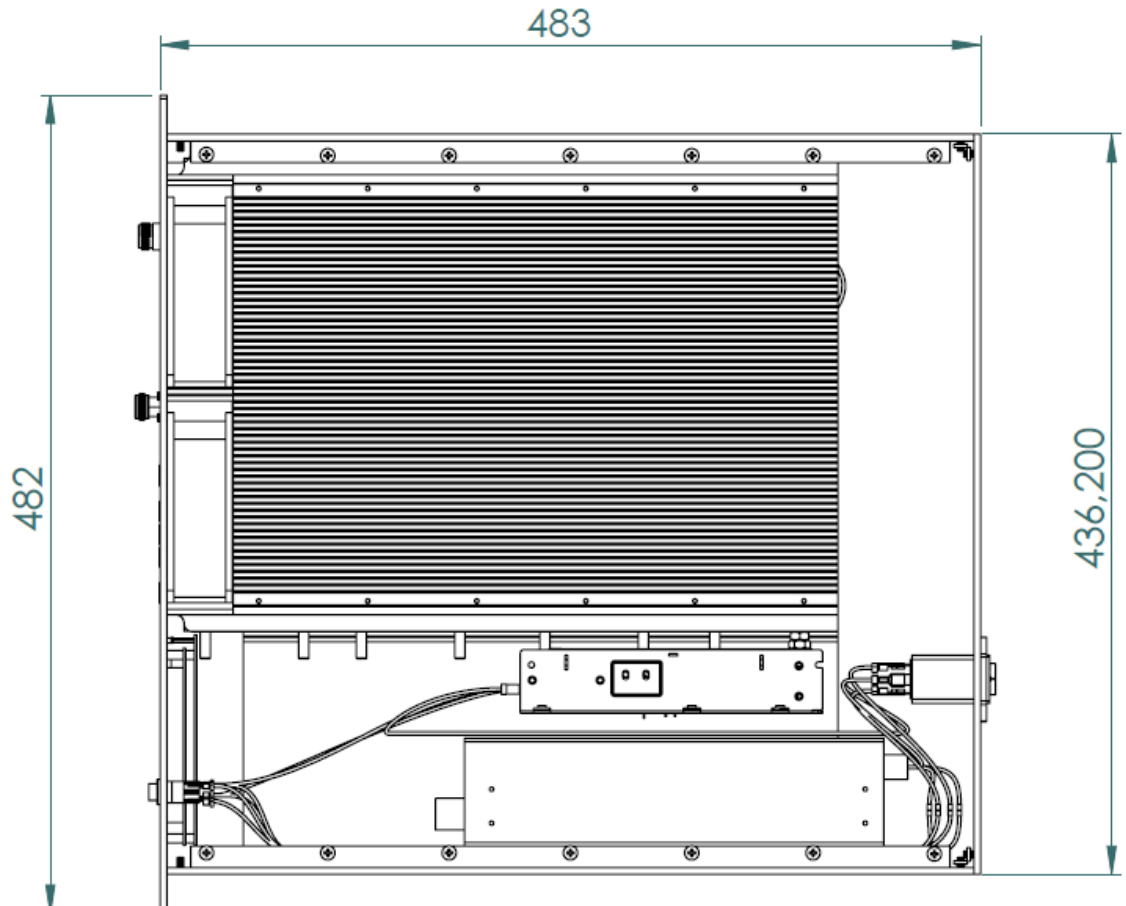
Figure 1 Simplified Block Diagram



**Figure 2 FRONT VIEW Outline: Dimensions 482 mm x 483 mm x 177.5 mm (18 31/32" x 19 1/64" x 6 31/32")**

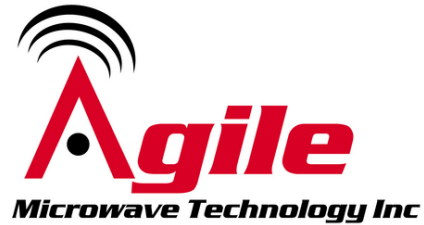


**Figure 3 BACK VIEW**



**Figure 4 TOP VIEW (COVER REMOVED)**

TABLE II CONNECTORS	
RF Input and Output	Type N Female
Ethernet	RJ-45



Contact us for custom configurations or options, special interfaces, and detailed electrical performance requirements for SSPAs. Our highly experienced team of engineers can quickly identify and implement innovative solutions using latest technology to improve performance and reduce cost.

- Additional functionality can be added.
- Agile Microwave Technology Inc is the logical choice for all your commercial or military RF/Microwave components/module/rack/system requirements.

<b>Model Number</b>	<b>Description</b>	<b>Hermeticity</b>	<b>Package</b>
AMT-A-501	See Table I	Non-Hermetic	RACK MOUNT Outline: See Figure 2
AMT-A-501MANUAL	MANUAL		

**Contact Information:**

**101 Bloomingdale Road  
Hicksville, NY 11801  
Phone: (516) 931-1760  
Fax: (212) 374-1153**



**[www.Agilemwt.com](http://www.Agilemwt.com) [sales@agilemwt.com](mailto:sales@agilemwt.com)**

AMTI reserves the right to change at any time without notice the design, specifications, function/form or availability of its products described herein. The buyer/customer has the responsibility to validate the performance for their applications. No liability is assumed as result of use of this product and no patent licenses are implied.

6/4/2015